

# FGT 1000 - 300 psi TEST & DRAIN VALVE

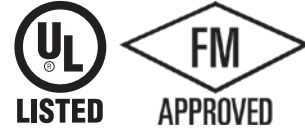

## PRODUCT OVERVIEW



**Test & Drain valve** with an integral sight glass assembly, provides a simplified means for testing of waterflow alarm devices and draining of feed mains. Test and drain valve is a 300 PSI rated single handle ball valve that was specifically designed to provide both the test function and the express drain function required for a wet fire sprinkler system. It include tamper resistant test orifice and sight glass for maximum visibility when operated. Available in size 1" , 1 ¼", 1 ½" & 2".

## Features

Model : FGT 1000  
 K-Factor : 5.6 (80), 8.0 (115)  
 Size : 1" - 2" (DN25 - DN50)  
 Working Pressure: 300 psi  
 Temperature: -10°C / +120°C  
 Approvals: UL & FM  
 Design: UL 258-2004  
 Thread Design: ISO 228/1

## Test and Drain Valve Connection details

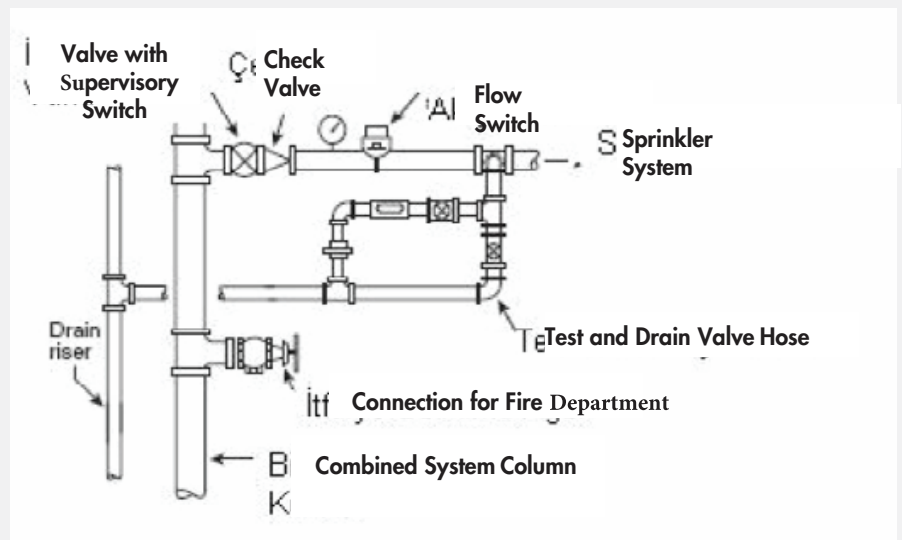

MODEL	DESCRIPTION
FGT 1000	TEST & DRAIN VALVE

# Technical Specification

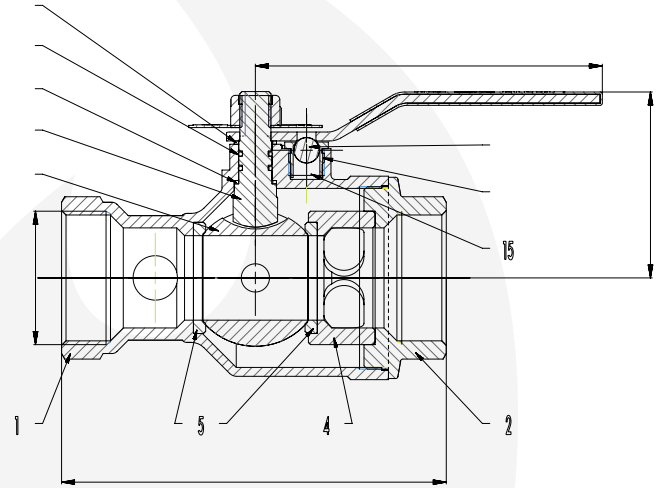
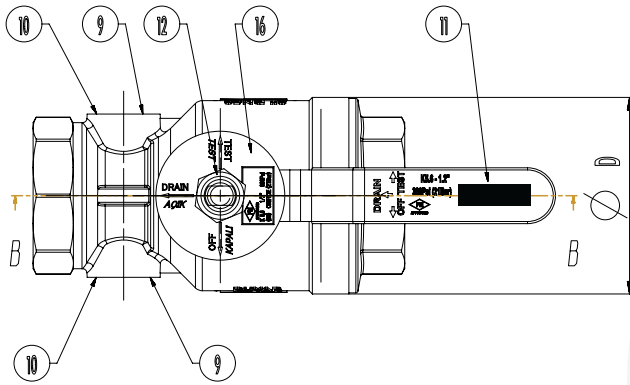

## Dimensions

Nominal Pressure	300 psi (20,7 bar)		
Nominal Diameter	DN	25-32	40-50
Valve Dimensions	G	1" - 1 1/4"	1 1/2" - 2"
	L	133	173
	C	126	156
	H	65	84
	D	60	92
Weight	KG.	1.4/1.3	3.5/3

## Material Specifications

NO	Part Name	Qty	Material
1	Body	1	CW617N / Brass
2	Bonnet	1	CW617N / Brass
3	Stem	1	AISI-304 /Stainless Steel
4	Bonnet Extension	1	CW617N / Brass
5	Ball Seat	2	PTFE
6	Ball	1	CW617N / Brass
7	Stem Seal	2	PTFE
8	O-Ring Seal	2	EPDM
9	Sight Glass	2	Acrylic
10	Sight Glass Gasket	2	EPDM
11	Lever	1	Si37/Steel (Vinyl Coated)
12	Nut With Fiber	1	6.8 / Steel
13	Bearing Ball Centering	1	C-1040 / Steel
14	Bearing Ball	1	AISI-304 / Stainless Steel
15	Spring	1	AISI-302 S. S / Spring Steel
16	Label Plate	1	AISI-304 / Stainless Steel

**RAWABI AL MAHFAR**

Tel: +966 59 218 4281

Fax: +966 53 500 2134

Email: info@rawabialmahfar.com

www.rawabialmahfar.com



Salah Ad Din Al Ayyubi Rd, Al Malaz,  
Riyadh 12842, Saudi Arabia



FS546607